

Assembly Instructions



PHOTON

Bluestreakequipment MAGNETICS
APPLICATION DRIVEN DESIGN

Bluestreak Equipment
1645 Hwy #3, Delhi, Ontario, Canada N4B 2W6

What's in the Box - Parts

AA) Photon Lower Frame, Drum and Magnet Assembly - 1 pc

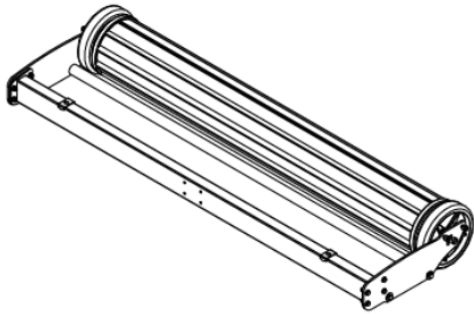

AB) Photon Debris Bins - 2 pcs

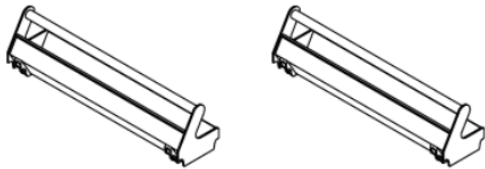

AC) Photon Tongue - 1 pc



AD) Photon Upper Frame Rods - 2 pcs



AE) Photon 6 Inch Caster Wheel - 1 pc



AF) Photon Right Caster Bracket - 1 pc



AG) Photon Left Caster Bracket - 1 pc



AH) Photon Upper Handles - 2 pcs



Ai) Photon Upper End Plates - 2 pcs

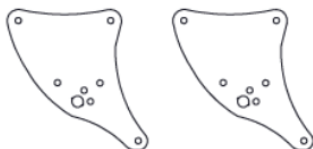

AJ) Photon Trailer Tongues - 2 pcs



AK) Photon Caster Spacer - 1 pc



What's in the Box - Fasteners & Small Parts

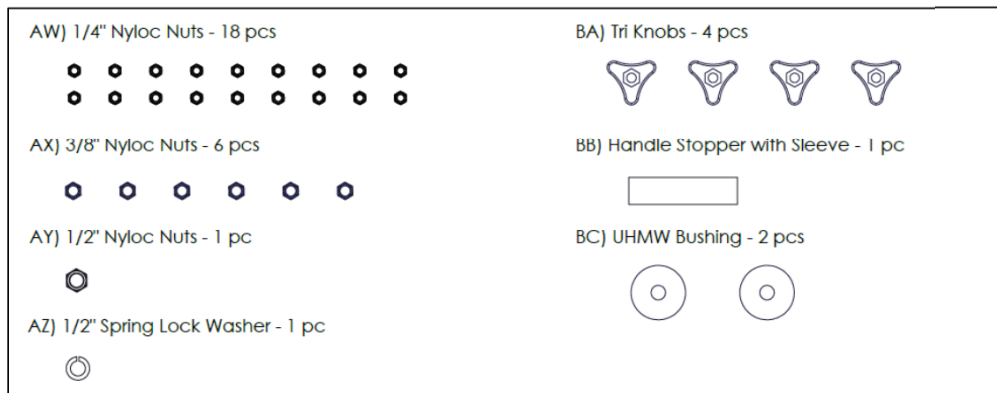
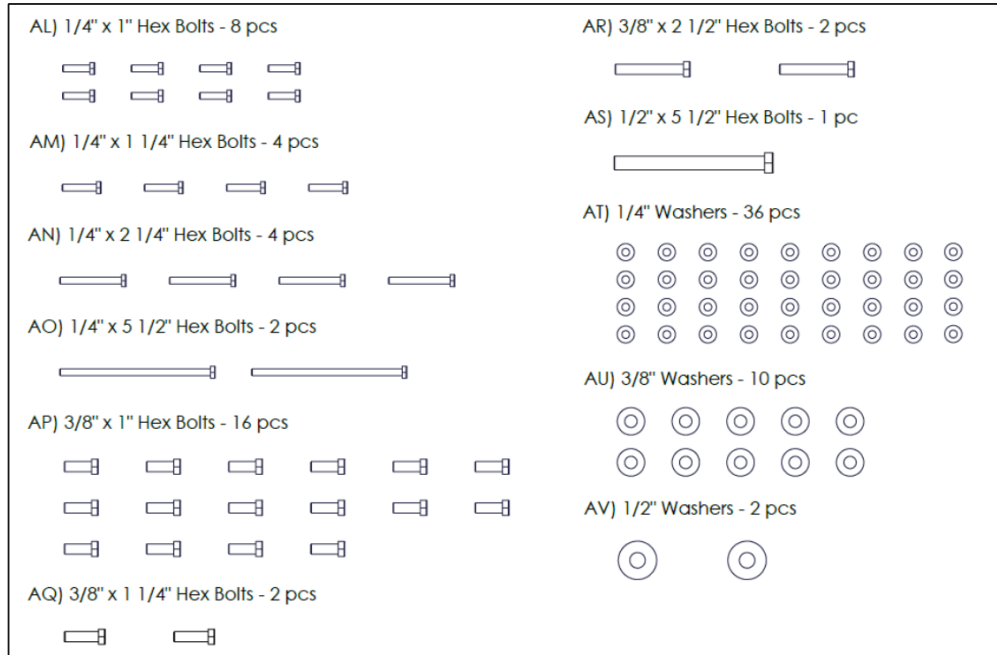

What's in the Box - Tools Needed

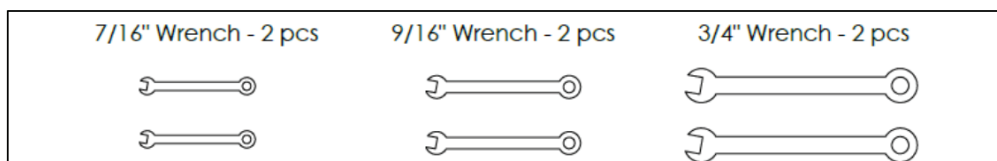

Step 1. Remove Bolts and Nuts from Lower End Plates

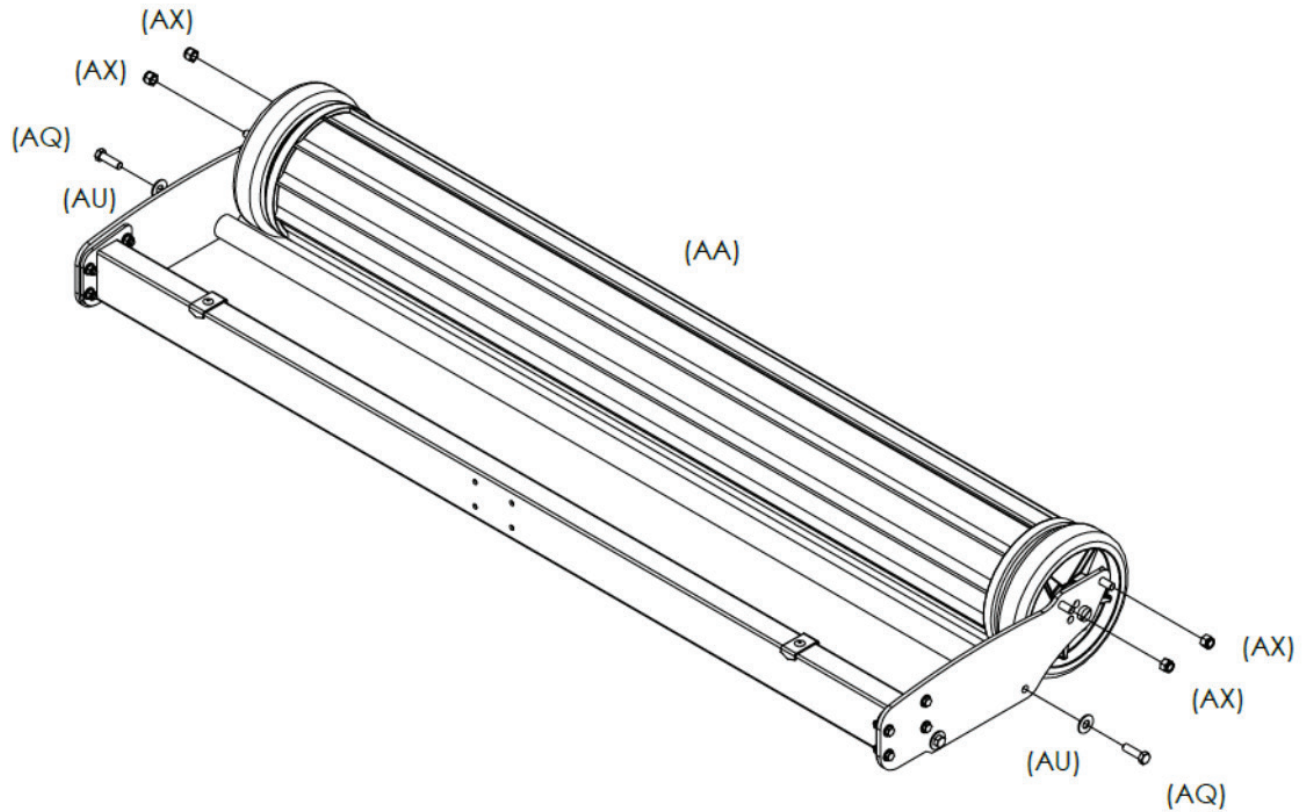

- (1) Remove Bolts and Nuts from Lower End Plates
 - a. Remove 1 pc 3/8" x 1 1/4" Hex Bolt (Item AQ) and its 3/8" Washer (Item AU) from one lower frame rod.
 - b. Remove 2 pcs 3/8" Nyloc Nuts (Item AX) from lower end plate.
 - c. Repeat for opposite side.

Step 2. Attach Upper End Plates to Lower End Plates

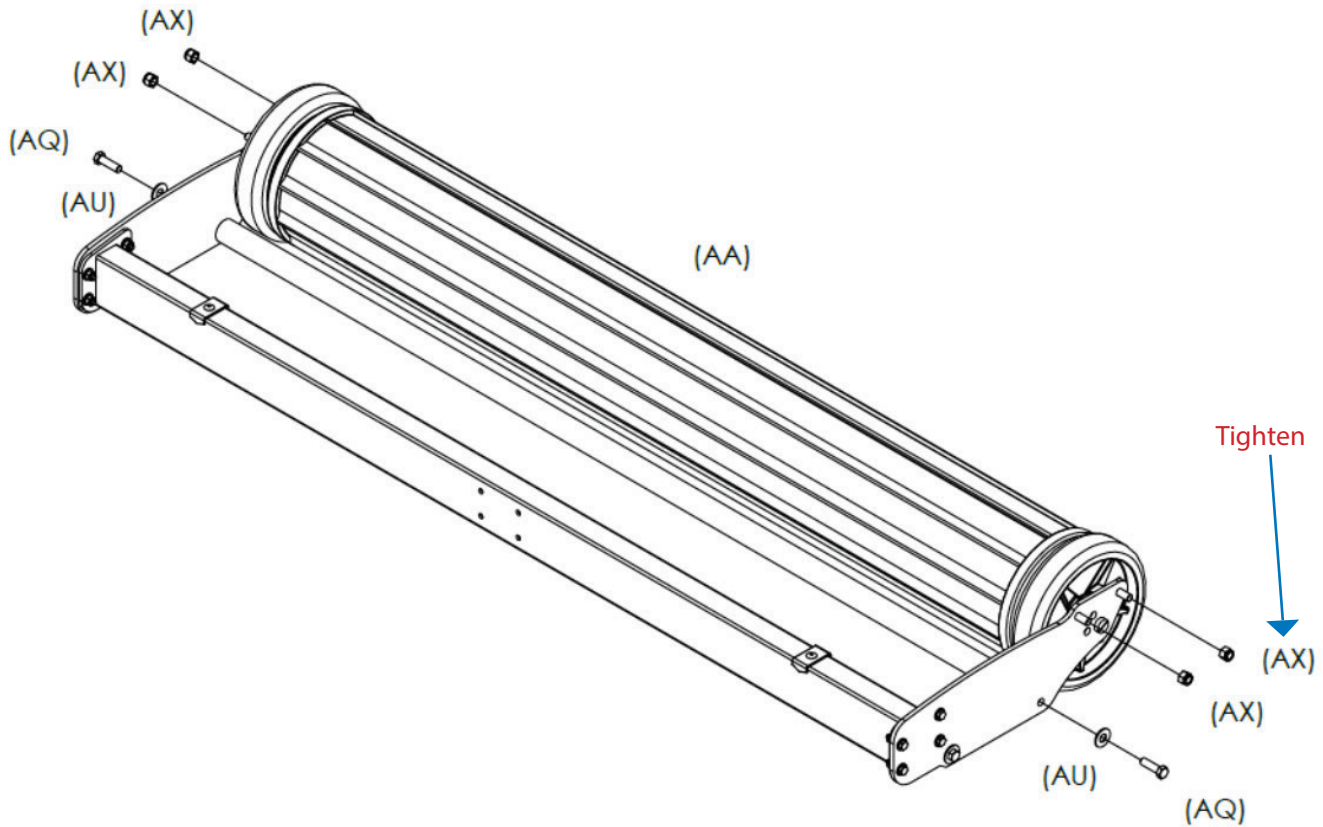

- (1) Attach Upper End Plates to Lower End Plates
 - a. Slide the upper end plate (Item Ai) onto the axle.
 - b. Attach upper end plate (Item Ai) to lower end plate on main assembly (Item AA) using 1 pc 3/8" x 1 1/4" Hex Bolt (Item AQ), 1 pc 3/8" Washer (Item AU), and 2 pcs 3/8" Nyloc Nuts (Item AX). Those are the bolts and nuts removed in the last step.
 - c. Tighten the 2 pcs Nyloc Nuts (Item AX). But do not tighten the bolt (Item AQ) on the lower frame.
 - d. Repeat for the opposite side.

Note: Try to align the holes on upper and lower end plates before tightening the nyloc nuts.

Note: Do not tighten other bolts until after step 4.

Step 3. Attach Upper Frame Rods

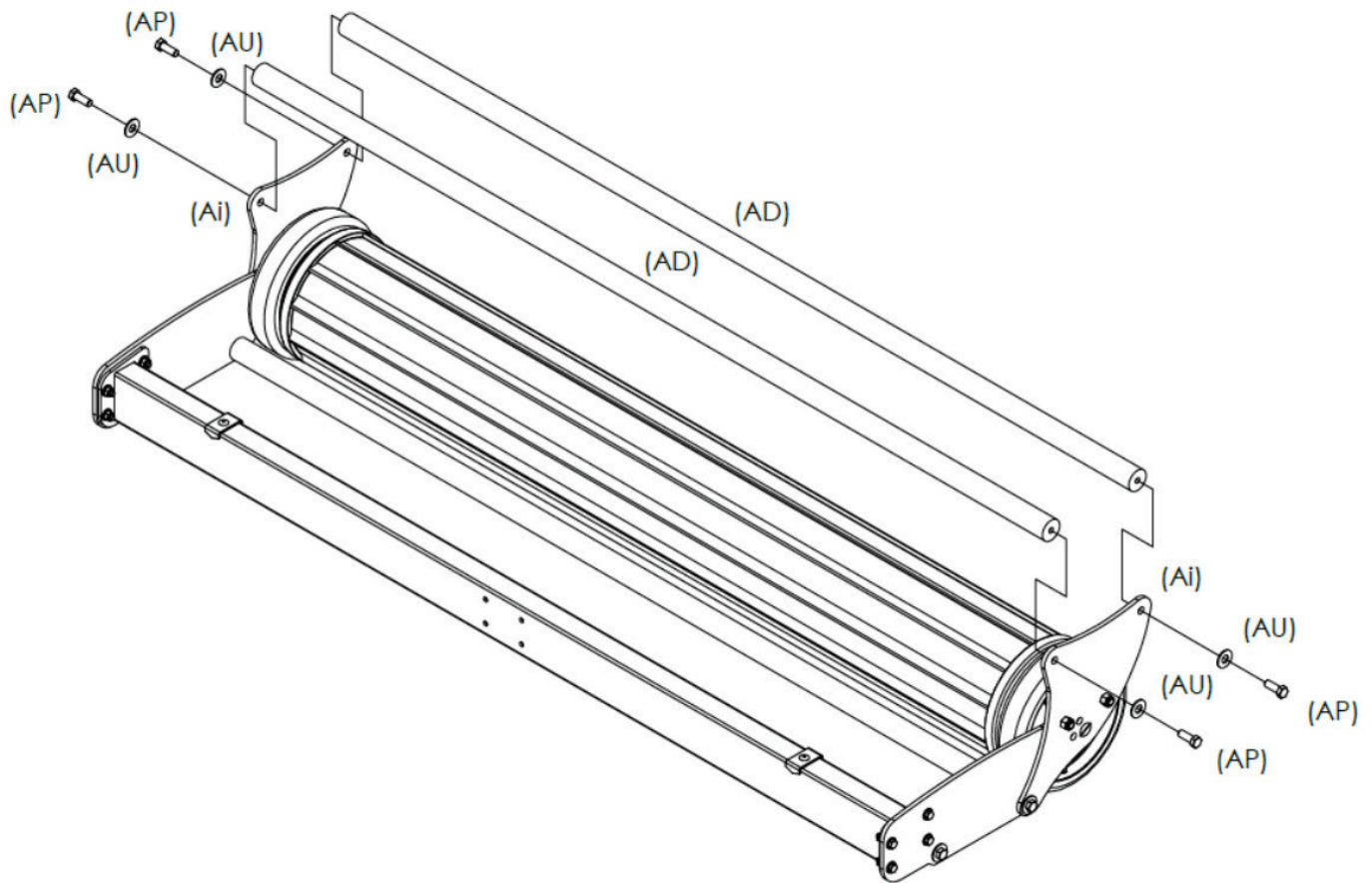

- (1) Attach Upper Frame Rods
 - a. Slide the 2 pcs upper frame rods (Item AD) between upper end plates (Item Ai). Attach using 4 pcs 3/8" x 1" Hex Bolts (Item AP) and 4 pcs 3/8" Washer (Item AU).

Note: Do not tighten these bolts until after step 4.

Step 4. Bolt Clamping Collar

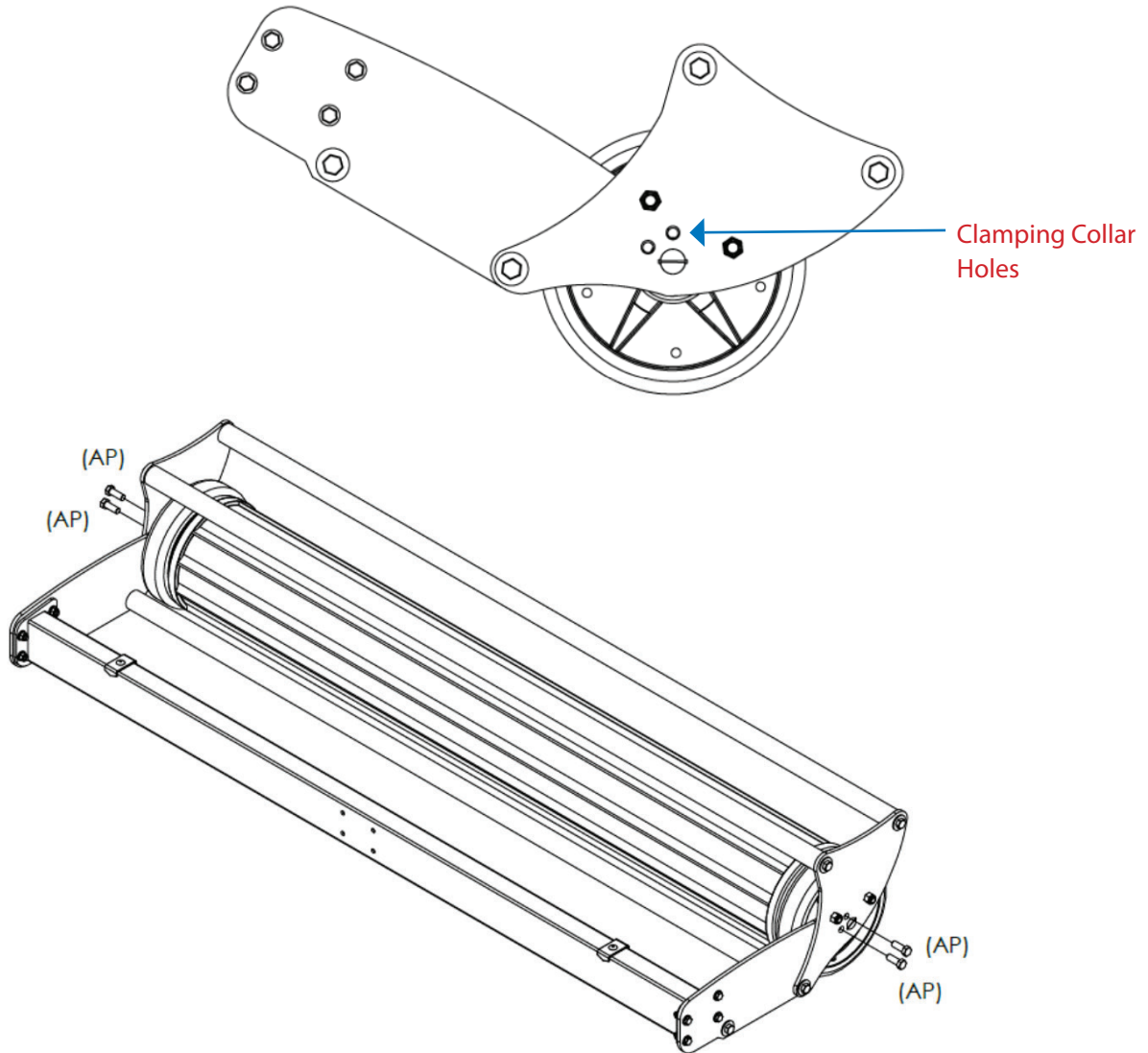

- (1) Bolt Frame to Clamping Collars
 - a. Lift the frame at the front, so that the 2 holes on the end plates align with the 2 holes on the clamping collar on each side.
 - b. Bolt the frame to clamping collar using 2 pcs 3/8" x 1" Hex Bolts (Item AP).
 - c. Repeat for the other side. Though at this time the holes should already be aligned.

Note: Tighten all the bolts.

Note: Tighten the bolts between caster brackets and front frame.

Step 5. Attach Left and Right Caster Brackets

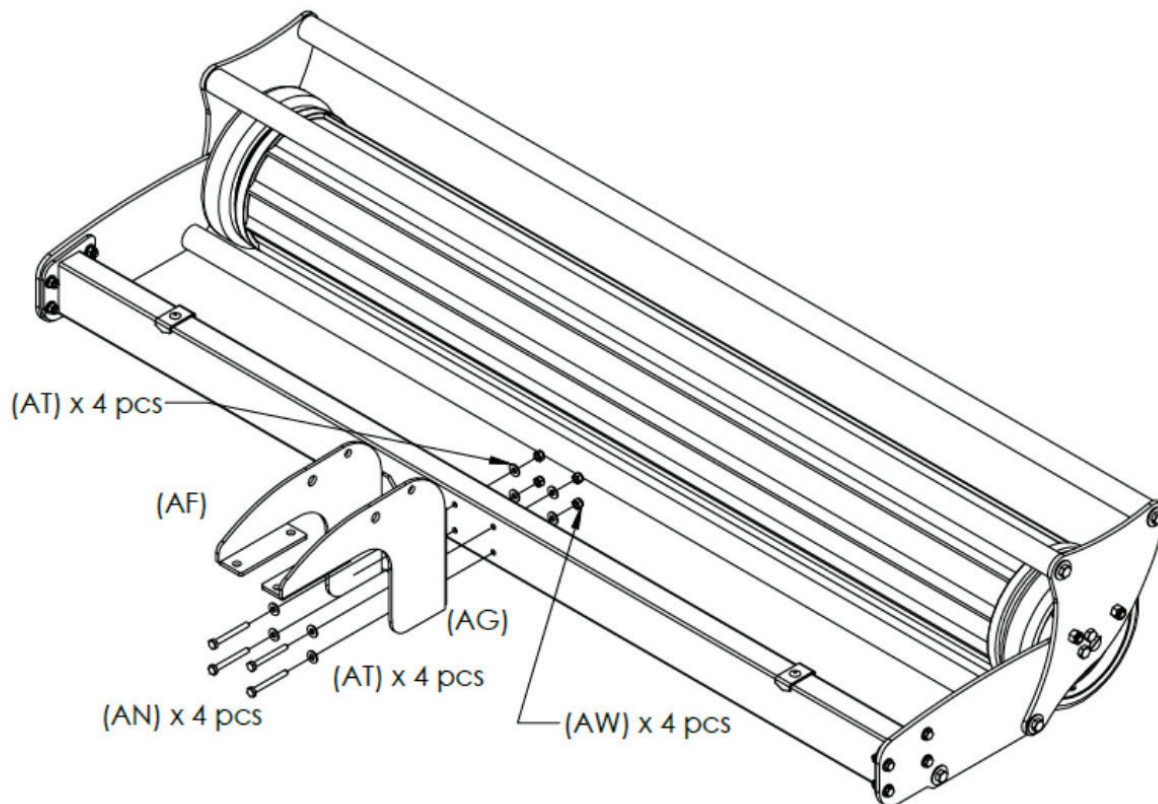

- (1) Attach Left and Right Caster Brackets
 - a. Attach left (Item AG) and right (Item AF) caster brackets to front frame using 4 pcs $\frac{1}{4}$ " x $2\frac{1}{4}$ " Hex Bolts (Item AN), 8 pcs $\frac{1}{4}$ " Washers (Item AT), and 4 pcs $\frac{1}{4}$ " Nyloc Nuts (Item AW).

Note: Do not tighten these bolts until after step 10.

Step 6. Attach Caster Wheel and Spacer onto the Brackets

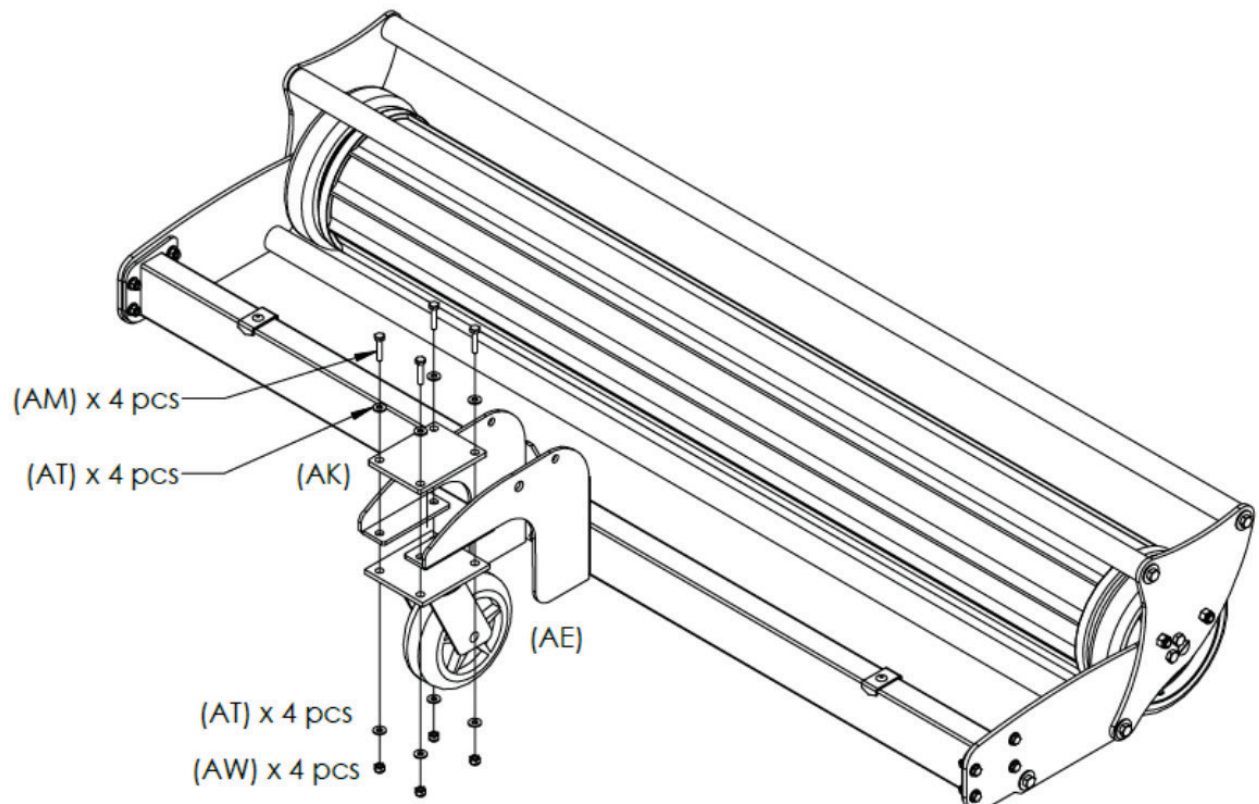

- (1) Attach Caster Wheel and Spacer onto the Brackets
 - a. Attach 6" caster wheel (Item AE) and caster spacer (Item AK) to the caster brackets using 4 pcs 1/4" x 1 1/4" Hex Bolts (Item AM), 8 pcs 1/4" Washers (Item AT), and 4 pcs 1/4" Nyloc Nuts (Item AW).

Note: Do not tighten these bolts until after step 10.

Step 7. Attach Handle Stopper

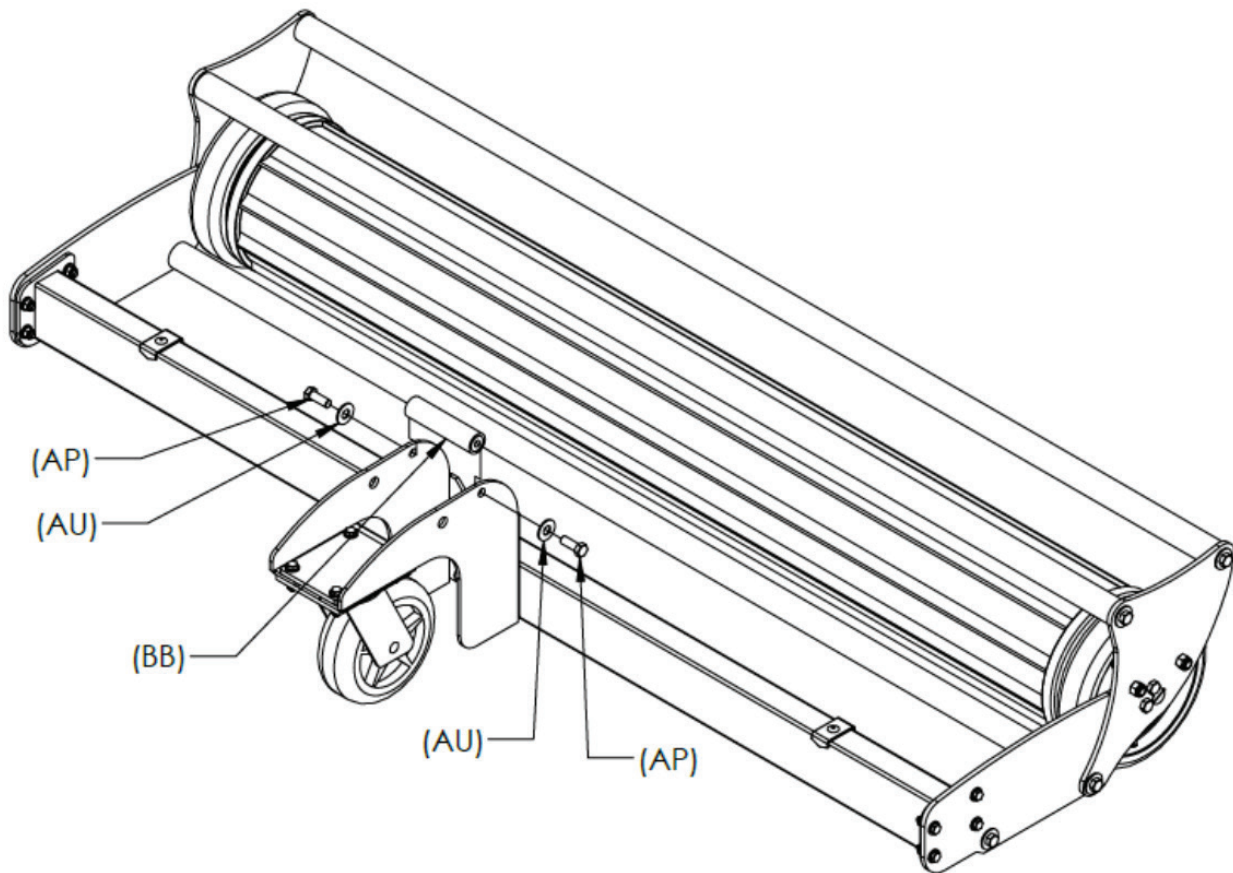

- (1) Attach Handle Stopper
 - a. Attach handle stopper (Item BB) between caster brackets using 2 pcs 3/8" x 1" Hex Bolts (Item AP), and 2 pcs 3/8" Washers (Item AU).

Note: Do not tighten these bolts until after step 10.

Step 8. Bolt Trailer Tongues to Tongue

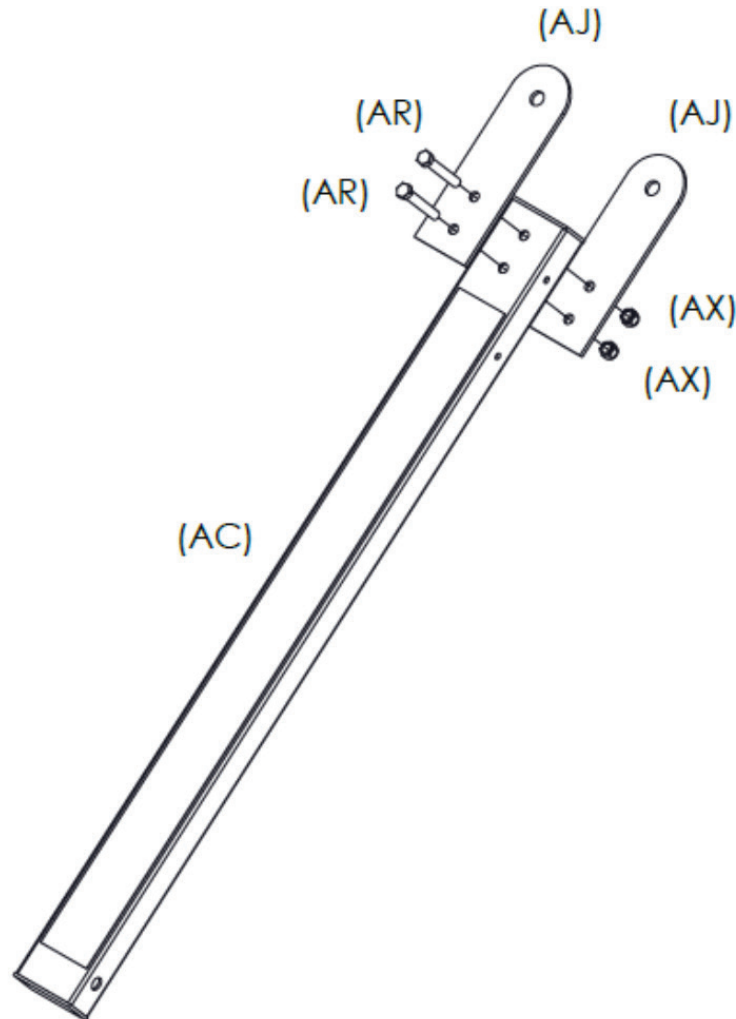

- (1) Bolt Trailer Tongues to Tongue
 - a. Bolt 2 pcs of trailer tongues (Item AJ) to tongue (Item AC) using 2 pcs 3/8" x 2 1/2" Hex Bolts (Item AR), and 2 pcs 3/8" Nyloc Nuts (Item AX).

Step 9. Attach Upper Handles

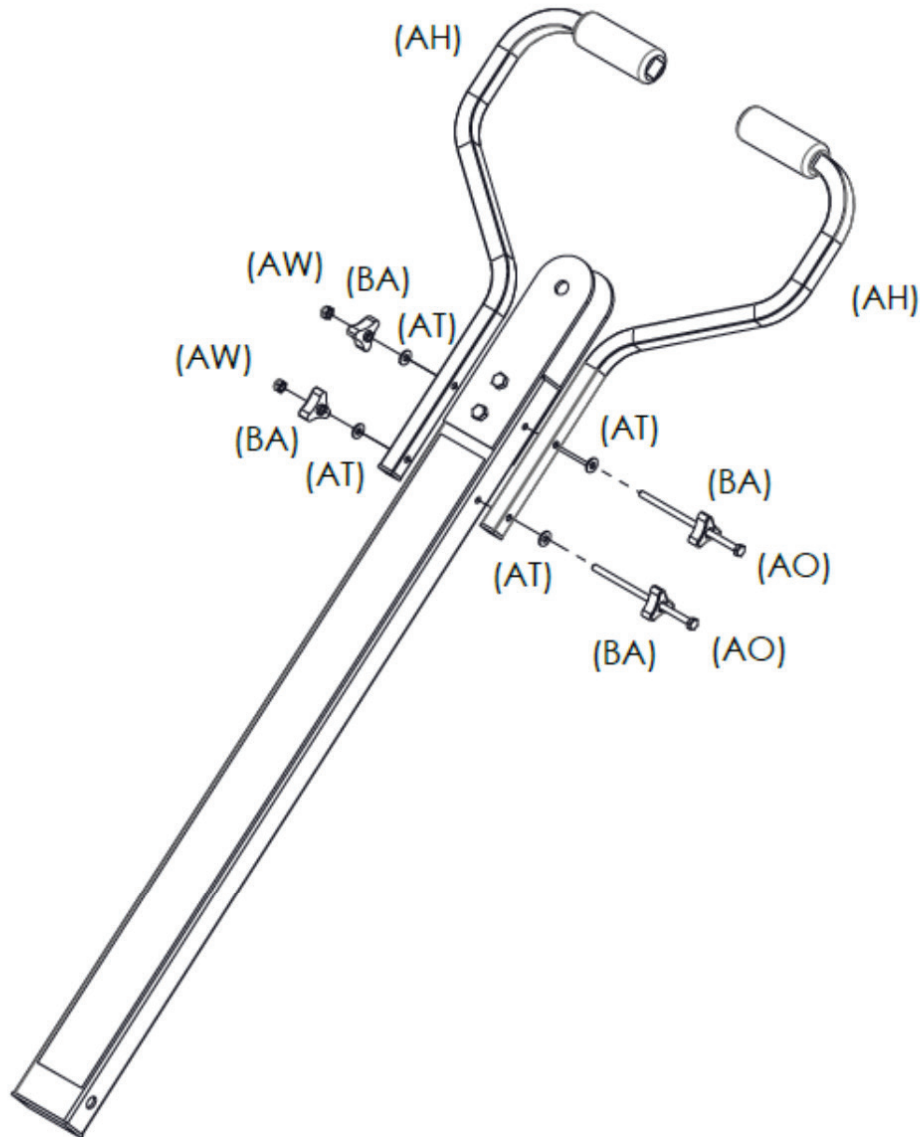

- (1) Attach Upper Handles
 - a. Attach upper handles (Item AH) to tongue assembly using 2 pcs $\frac{1}{4}$ " x $5\frac{1}{2}$ " Hex Bolts (Item AO), 4 pcs $\frac{1}{4}$ " Washers (Item AT), 2 pcs $\frac{1}{4}$ " Nyloc Nuts (Item AW), and 4 pcs Tri Knobs (Item BA).

Step 10. Attach Tongue Assembly with Bushings

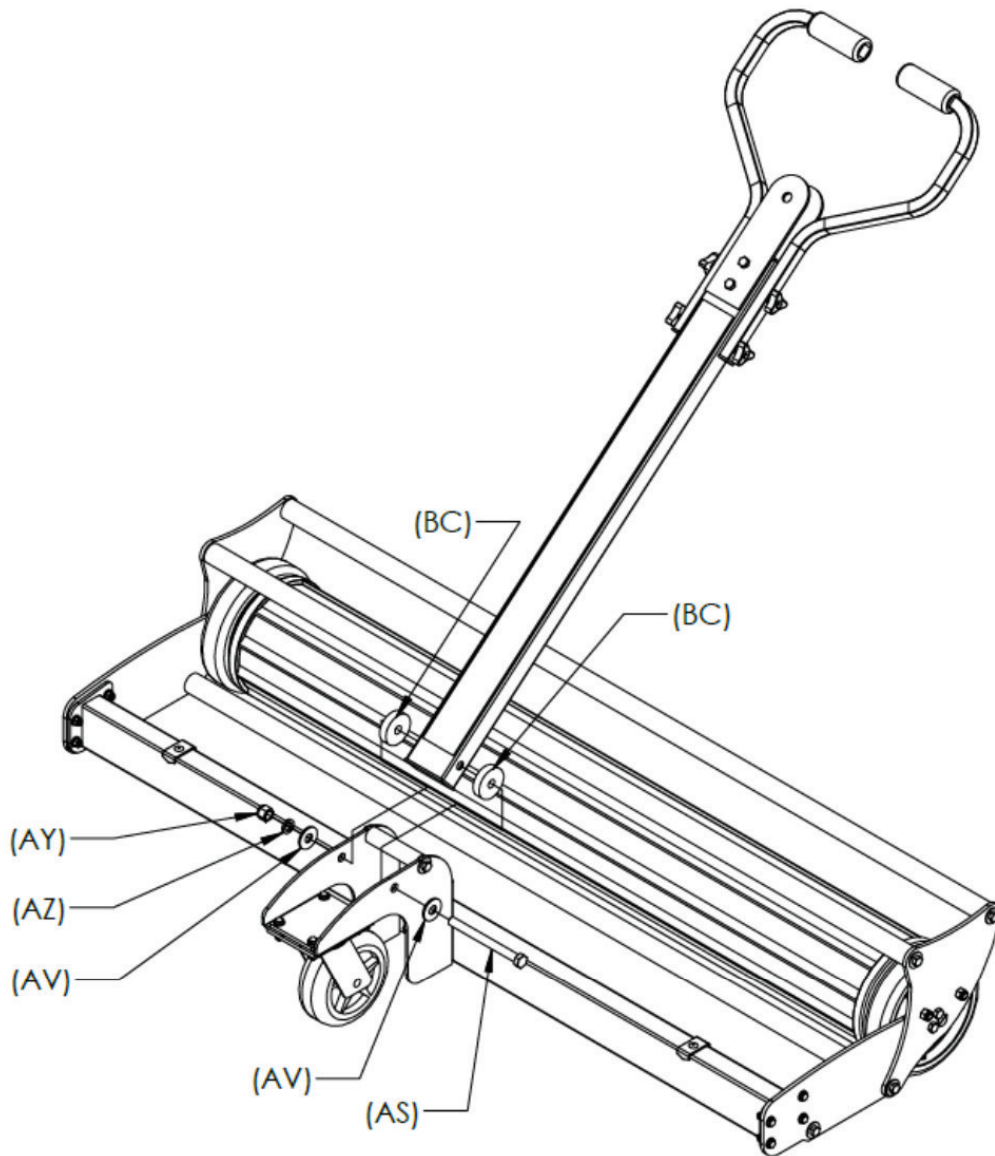

- (1) Attach Tongue Assembly with Bushings
 - a. Attach tongue assembly and 2 pcs lower tongue bushings (Item BC) to caster brackets using 1 pc $\frac{1}{2}$ " x $5\frac{1}{2}$ " Hex Bolt (Item AS), 2 pcs $\frac{1}{2}$ " Washers (Item AV), 1 pc $\frac{1}{2}$ " Spring Lock Washer (Item AZ), and 1 pc $\frac{1}{2}$ " Nyloc Nut (Item AY).

Note: Tighten all the bolts.

Step 11. Set Debris Bins in Place

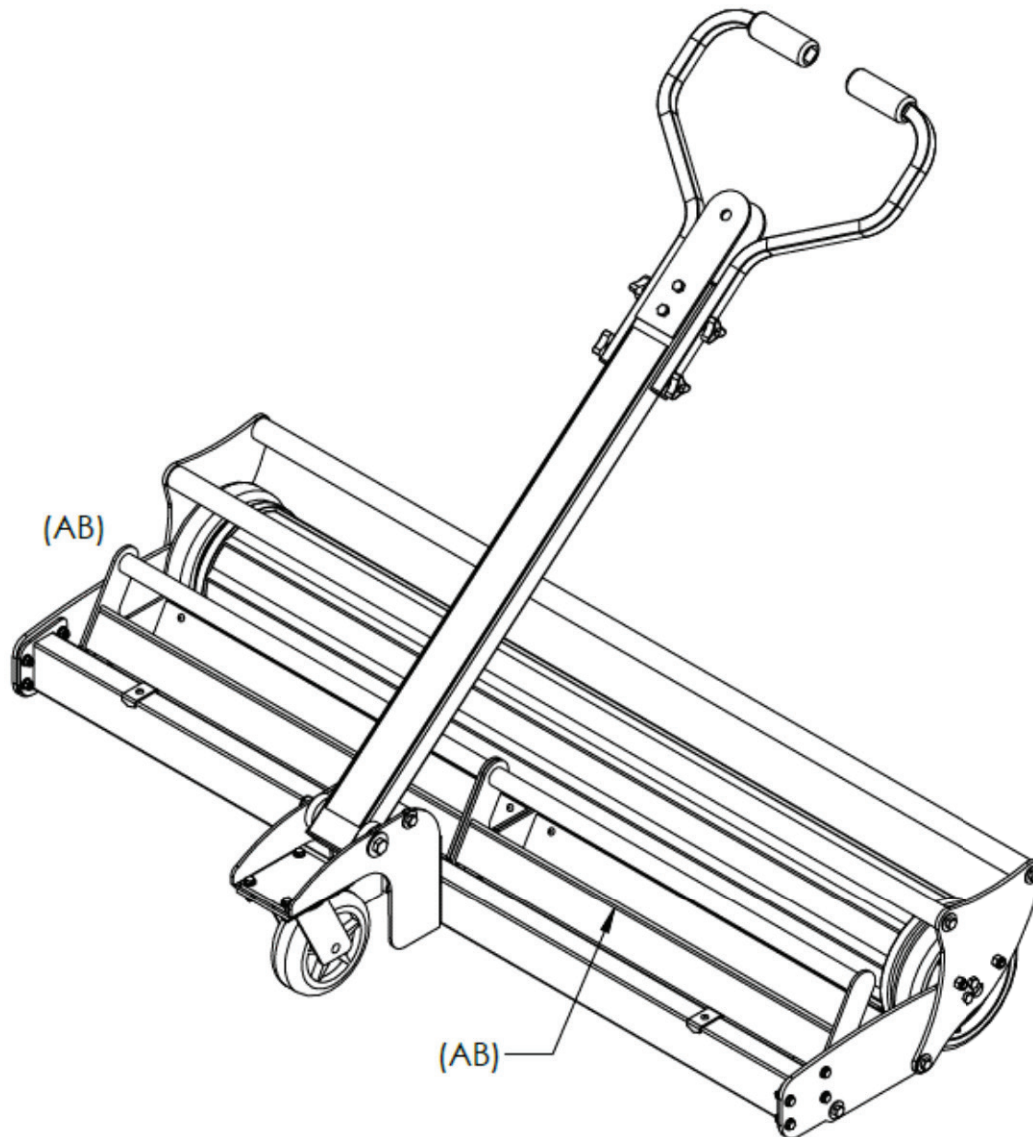

- (1) Set Debris Bins in Place
 - a. Set the debris bins (Item AB) in front of the magnetic sweeper on top of the lower frame rods.

Bluestreak Equipment • 1645 Hwy #3, Delhi, Ontario, Canada N4B 2W6

www.blustreakequipment.com